

REVISION	
REV	DESCRIPTION
E	RELEASE/CHANGE PER ECO-R199190

Power Supply Board Hardware Requirements Specification

COVIDIEN 6135 Gunbarrel Avenue Boulder, CO 80301 Proprietary and Confidential	TITLE: Power Supply Board Hardware Requirements Specification, PB 540	DOCUMENT NUMBER 10025029 SHEET 1 of 19	REV E
---	---	---	-----------------

PROPRIETARY & CONFIDENTIAL

FOR INTERNAL USE ONLY

This document may not be copied, disclosed, or used in whole or in part without the consent of COVIDIEN.

© 2008 COVIDIEN All Rights Reserved.

TABLE OF CONTENTS

1.0	INTRODUCTION.....	3
1.1	PURPOSE.....	3
1.2	SCOPE.....	3
1.3	REVISION HISTORY.....	3
2.0	GLOSSARY/ACRONYMS.....	3
3.0	OVERVIEW.....	5
3.1	INPUT DESCRIPTION.....	6
3.2	OUTPUT DESCRIPTION.....	6
4.0	ELECTRICAL REQUIREMENTS.....	7
4.1	AC/DC CONVERTER.....	7
4.2	AC INPUT.....	7
4.3	VACDC OUTPUT.....	7
4.4	DC INPUT.....	7
4.5	BATTERY FUNCTION.....	7
5.0	CALCULATOR.....	8
6.0	SWITCHOVER.....	8
6.1	GENERAL.....	8
6.2	DC LOSS MANAGEMENT.....	10
6.3	AC LOSS MANAGEMENT.....	10
6.4	POWER SOURCE AVAILABILITY.....	11
7.0	COOLING FAN FUNCTIONS.....	12
8.0	REGULATOR FUNCTIONS.....	12
8.1	24V REGULATOR.....	12
8.2	5V REGULATOR.....	12
8.3	3,3V REGULATOR.....	12
8.4	3V REFERENCE REGULATOR.....	12
9.0	SYSTEM INTERFACES.....	13
9.1	USB GATEWAY.....	13
9.2	CPU BOARD INTERFACE.....	13
9.3	PC / SYSTEM COMMUNICATION.....	13
9.4	TURBINE BOARD INTERFACE.....	13
9.5	INTERCONNECTS.....	14
10.0	MECHANICAL REQUIREMENTS.....	18
10.1	SIZE.....	18
10.2	MOUNTING.....	18
10.3	COOLING.....	18
10.4	FABRICATION.....	19
10.5	PROTECTION.....	19
10.6	LABELLING.....	19
11.0	PACKAGING REQUIREMENTS.....	19

COVIDIEN 6135 Gunbarrel Avenue Boulder, CO 80301 Proprietary and Confidential	TITLE: Power Supply Board Hardware Requirements Specification, PB 540	DOCUMENT NUMBER 10025029 SHEET 2 of 19	REV E
---	---	---	-----------------

PROPRIETARY & CONFIDENTIAL **FOR INTERNAL USE ONLY**

This document may not be copied, disclosed, or used in whole or in part without the consent of COVIDIEN.

© 2008 COVIDIEN All Rights Reserved.

1.0 INTRODUCTION

1.1 Purpose

The purpose of this document is to provide the requirements for the Power Supply Board.

1.2 Scope

This document provides the requirements for the Power Supply Board used in PB560, PB540 and PB520 products.

1.3 REVISION HISTORY

Revision	Date	Author	Change Description
A	05/27/08	S. Ricard	Initial Release of Specification.
B	09 Sep 08	F.Cotteaux	Add note on the IPC Class II/III requirement
C	03-Nov-08	G. Sanchez	Clarified requirements, updated format, Added priority of the power sources, clarified when charging is allowed
D	20-Jan-2009	G. Sánchez	Incorporate redlines from Verification Review.
E	21-july-2011	R.Kumar	Update requirement HWSSUB7 as per CDP # 10062350

2.0 Glossary/Acronyms

Acronym	Definition
°C	Celsius Degree
A	Ampere
ac	Alternating Current
CPU	Central Processing Unit
DC	Direct Current
EEPROM	Electrically Erasable Programmable Read Only Memory
GND	Electrical Ground
ICSP	In Circuit Serial Programmer
Kb	Kilobytes
kHz	Kilo Hertz
LED	Light Emitting Diodes
Mb	Megabytes
mA	Milliamps DC
mbar	Millibar
ms	Milli Seconds
ns	Nano Seconds
O ₂	Oxygen
PC	Personal Computer
PCBA	Printed Circuit Board Assembly

COVIDIEN 6135 Gunbarrel Avenue Boulder, CO 80301 Proprietary and Confidential	TITLE: Power Supply Board Hardware Requirements Specification, PB 540	DOCUMENT NUMBER	REV
		10025029	E
		SHEET 3 of 19	

PROPRIETARY & CONFIDENTIAL

FOR INTERNAL USE ONLY

This document may not be copied, disclosed, or used in whole or in part without the consent of COVIDIEN.

© 2008 COVIDIEN All Rights Reserved.

PWM	Pulse Width Modulation
rpm	Revolutions per minute
sccm	Square centimeter cubic per minute
SPI	Serial Peripheral Interface
UART	Universal Asynchronous Receiver Transmitter
USB	Universal Serial Bus
V	Volt
VDC	DC Voltage
W	Watt

<p>COVIDIEN 6135 Gunbarrel Avenue Boulder, CO 80301 Proprietary and Confidential</p>	<p>TITLE: Power Supply Board Hardware Requirements Specification, PB 540</p>	<p>DOCUMENT NUMBER 10025029 SHEET 4 of 19</p>	<p>REV E</p>
---	--	--	-------------------------

REVISION	
REV	DESCRIPTION
E	RELEASE/CHANGE PER ECO-R199190

3.0 OVERVIEW

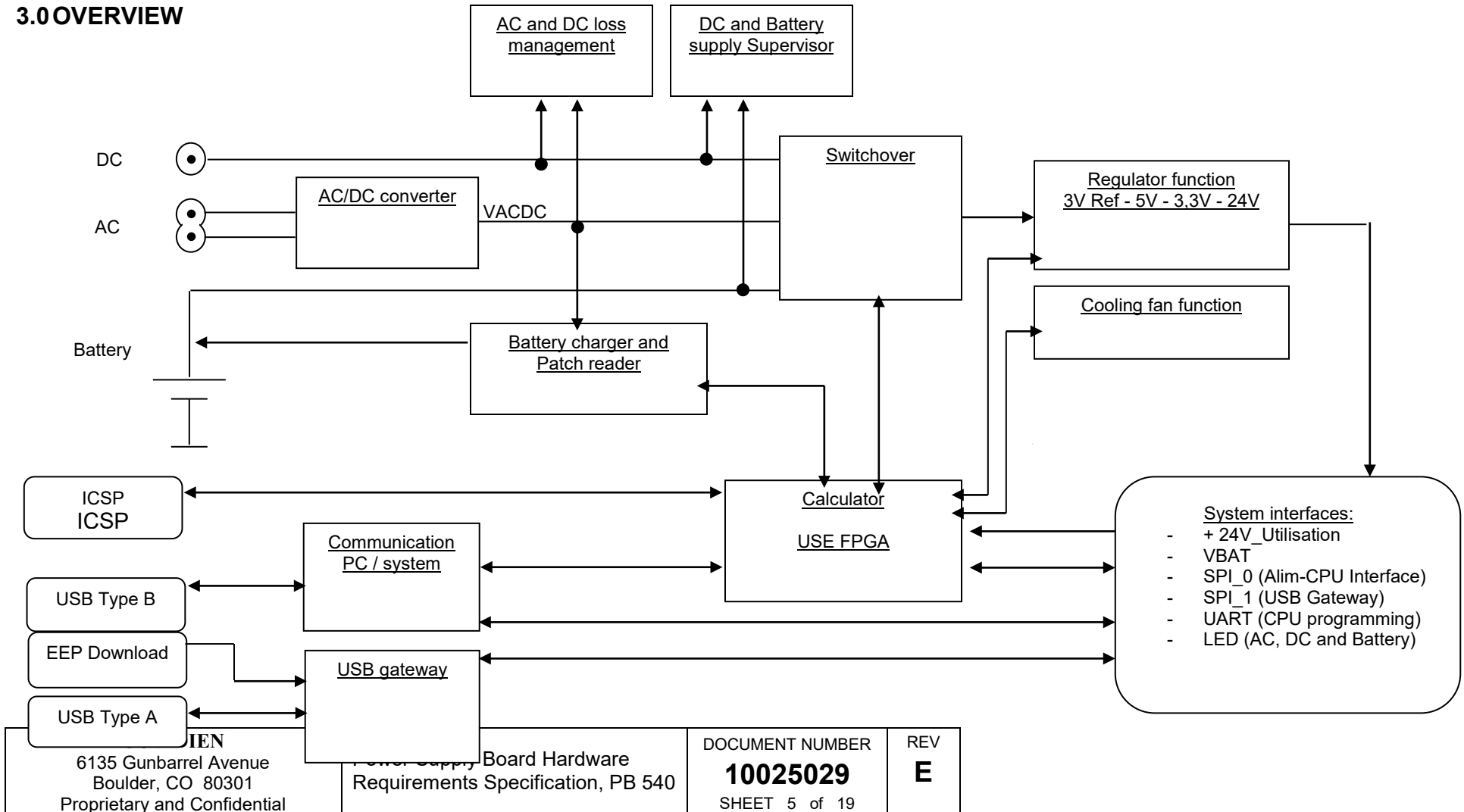

COVIDIEN
6135 Gunbarrel Avenue
Boulder, CO 80301
Proprietary and Confidential

Power Supply Board Hardware
Requirements Specification, PB 540

DOCUMENT NUMBER	REV
10025029	E
SHEET 5 of 19	

REVISION	
REV	DESCRIPTION
E	RELEASE/CHANGE PER ECO-R199190

3.1 Input description

- **External DC voltage:** External direct current power supply allowing input voltage from 12V to 33V. Allow ventilator to be used in ventilation mode only but doesn't allow battery charge.
- **AC power supply:** Powers the AC/DC converter which supplies 33V DC.
- **Battery:** Ventilator internal battery. Technology Li-Ion – 26V Nominal Voltage.
- **USB Type B:** Communication and programming interface between PC and CPU or Power Supply management microcontroller.
- **USB Type A:** Interface used for mass storage peripheral connection.
- **Main switch:** Used for starting ventilator.
- **ICSP:** Microcontroller programming interface.
- **USB EEPROM Download:** USB gateway programming interface.

3.2 Output description

- **24V Util:** Regulate voltage to power other boards.
- **AC LED:** Direct connection between keyboards AC LED and microcontroller.
- **DC LED:** Direct connection between keyboards DC LED and a linear regulator to indicate direct current voltage.
- **Battery LED:** Direct connection between keyboards Battery LED and microcontroller.
- **SPI_0:** Bus allowing data exchange between CPU board and power management board.
- **SPI_1:** Bus allowing data exchange between CPU board and USB gateway on power management board.
- **VBAT:** Direct connection between CPU board and battery for voltage measurement.
- **UART ST10:** Bus allowing communication between Pc and CPU board via USB/2-UART converter.

COVIDIEN 6135 Gunbarrel Avenue Boulder, CO 80301 Proprietary and Confidential	TITLE: Power Supply Board Hardware Requirements Specification, PB 540	DOCUMENT NUMBER 10025029 SHEET 6 of 19	REV E
---	---	---	-----------------

PROPRIETARY & CONFIDENTIAL

FOR INTERNAL USE ONLY

This document may not be copied, disclosed, or used in whole or in part without the consent of COVIDIEN.

© 2008 COVIDIEN All Rights Reserved.

4.0 ELECTRICAL REQUIREMENTS

4.1 AC/DC Converter

HWSSUB1 The AC/DC converter shall comply with **UL 60601-1 Medical Electrical Equipment - Part 1: General Requirements for Safety** June 30, 2003.

4.2 AC Input

HWSSUB77 The Power Supply board shall monitor the AC/DC converter output (VACDC) within a 0 to 36 VDC range with an accuracy of +/- 1VDC.

The AC/DC converter supports an AC input voltage range of 90 VAC to 250 VAC.
The AC/DC converter works at AC frequencies of 50 Hz through 60Hz.

4.3 VACDC Output

The AC/DC converter produces a DC output of 33 VDC +/- 5%.
The AC/DC converter is capable of supplying 3 A of current.

4.4 DC Input

HWSSUB81 The DC Input shall support a voltage range of 10.8 VDC to 33VDC.
HWSSUB80 The DC Input shall draw less than 3A (100W).

HWSSUB2 The Power Supply board shall monitor the DC input within a 0 to 36 VDC range with an accuracy of +/- 1VDC.

HWSSUB15 The Power Supply board shall provide a reverse connection protection for the DC supplies.

4.5 Battery function

4.5.1 Battery monitoring

HWSSUB3 The Power Supply board shall monitor the battery voltage within a range 0V to 33V, with an accuracy of +/-1V.

HWSSUB4 The Power Supply board shall measure charge and discharge battery current within a range from -3A to +1.5A with an accuracy of +/-200mA.

COVIDIEN 6135 Gunbarrel Avenue Boulder, CO 80301 Proprietary and Confidential	TITLE: Power Supply Board Hardware Requirements Specification, PB 540	DOCUMENT NUMBER 10025029 SHEET 7 of 19	REV E
---	---	---	-----------------

PROPRIETARY & CONFIDENTIAL

FOR INTERNAL USE ONLY

This document may not be copied, disclosed, or used in whole or in part without the consent of COVIDIEN.

© 2008 COVIDIEN All Rights Reserved.

4.5.2 Battery charger

The Power Supply board shall charge the battery only when AC voltage is present.

HWSSUB5 The Power Supply board calculator shall be able to stop the charge when the battery is charged to 29.4VDC +/- 0.15VDC.

HWSSUB6 The Power Supply board shall monitor the battery charge voltage within a range 0V to 33V, with an accuracy of +/-1V.

HWSSUB7 The Power Supply board shall be able to adjust the battery charge with a constant current level (accuracy +/-150mA) in a range of 300mA -1500mA.

A Lithium-Ion battery charge cycle happens in two steps:

1. The battery will initially be charged at constant current:
 - 500mA during ventilation
 - 1500mA when the system is not ventilating
2. The end of charge voltage is held until current falls under 150mA and the charger turn off.

4.5.3 Battery patch reading and writing

HWSSUB8 The Power Supply board shall provide the ability of communicating with the internal memory of the battery.

The battery internal memory is a One-Wire type (DS2431).

4.5.4 Battery temperature measurement

HWSSUB9 The Power Supply board shall provide the ability to measure battery temperature from -30°C to +80°C with an accuracy +/-3°C.

5.0 CALCULATOR

HWSSUB18 System shall integrate a numeric calculator. It will be programmable in circuit. This circuit is used to manage the battery charge, the commutation condition, the alarms, the SPI CPU communication.

HWSSUB19 The Power Supply board shall allow the calculator startup (5VDC regulator) either:

When main switch is on and external DC power or battery source is available or

When AC power is available (in order to manage the battery charger even if the main switch is off)

6.0 SWITCHOVER

6.1 General

HWSSUB14 The Power Supply board shall accept an input from three sources: AC voltage, external DC input, or a battery.

The Power Supply board shall use three power sources in listed priority. If valid power is restored in a higher priority that supply will be used as the source:

- 1 – AC Input
- 2 – DC Input
- 3 – Internal Battery power

HWSSUB16 The Power Supply board shall start the 24VDC regulator when the main switch is on and a power source is available (including AC,DC or Battery supply restoration after accidental power supply loss)

COVIDIEN 6135 Gunbarrel Avenue Boulder, CO 80301 Proprietary and Confidential	TITLE: Power Supply Board Hardware Requirements Specification, PB 540	DOCUMENT NUMBER 10025029 SHEET 8 of 19	REV E
---	---	---	-----------------

PROPRIETARY & CONFIDENTIAL

FOR INTERNAL USE ONLY

This document may not be copied, disclosed, or used in whole or in part without the consent of COVIDIEN.

© 2008 COVIDIEN All Rights Reserved.

HWSSUB17 The Power Supply board shall provide circuitry to supply 24VDC in the event of a controller malfunction when a power source is available.

COVIDIEN 6135 Gunbarrel Avenue Boulder, CO 80301 Proprietary and Confidential	TITLE: Power Supply Board Hardware Requirements Specification, PB 540	DOCUMENT NUMBER 10025029 SHEET 9 of 19	REV E
---	---	---	-----------------

PROPRIETARY & CONFIDENTIAL

FOR INTERNAL USE ONLY

This document may not be copied, disclosed, or used in whole or in part without the consent of COVIDIEN.

© 2008 COVIDIEN All Rights Reserved.

6.2 DC loss management

HWSSUB10 The Power Supply board shall trigger a calculator interruption by a comparator output in order to manage a power supply commutation if the external DC supply if the external DC voltage drops below 9.75VDC, +/- 0.80VDC. The comparator watching the external DC voltage shall be rearmed if the external DC voltage goes above 10VDC, +/-0.8VDC.

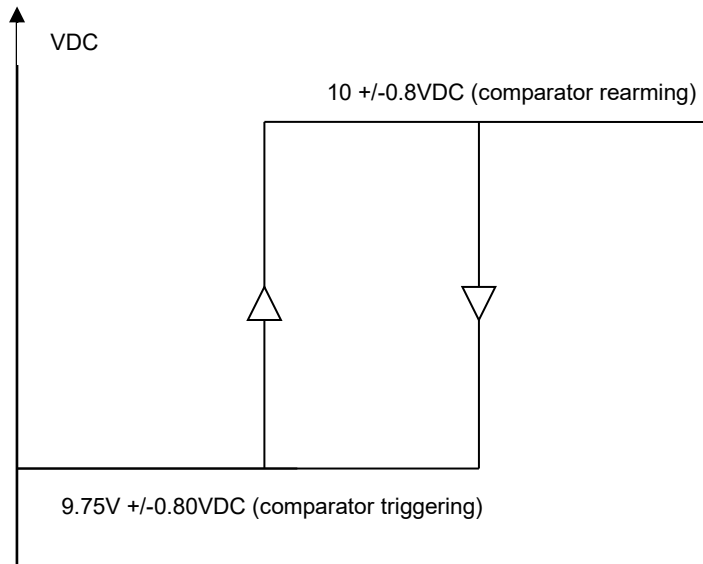

6.3 AC loss management

HWSSUB11 The Power Supply board shall trigger a calculator interruption by a comparator output in order to manage a power supply switch if the VACDC voltage drops below 24.0VDC, +/- 1.0VDC. The comparator shall be rearmed if the external DC voltage goes above 29.0VDC, +/-1.0VDC.

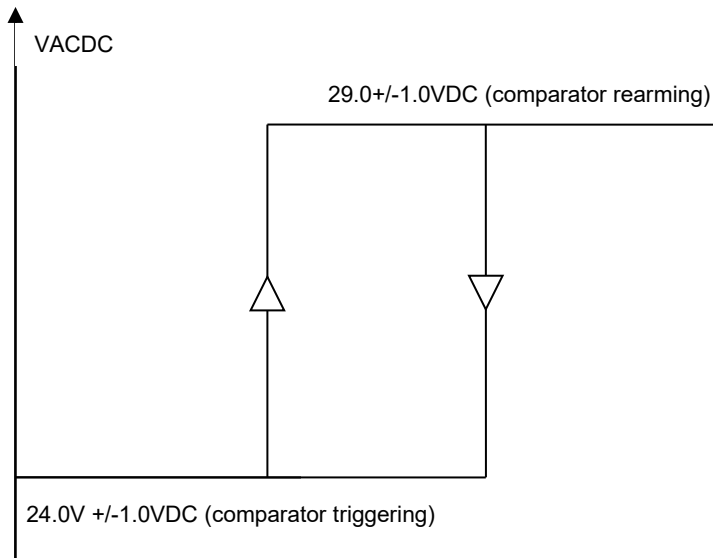

COVIDIEN 6135 Gunbarrel Avenue Boulder, CO 80301 Proprietary and Confidential	TITLE: Power Supply Board Hardware Requirements Specification, PB 540	DOCUMENT NUMBER 10025029 SHEET 10 of 19	REV E
---	---	--	-----------------

PROPRIETARY & CONFIDENTIAL

FOR INTERNAL USE ONLY

This document may not be copied, disclosed, or used in whole or in part without the consent of COVIDIEN.

© 2008 COVIDIEN All Rights Reserved.

6.4 Power source availability

6.4.1 Battery availability

HWSSUB12 The system shall cut-off the battery power supply if the battery voltage drop below 20.38VDC +/- 0.52VDC and the system shall allow again the use of battery power if the battery voltage goes back above 24.58VDC +/- 0.65VDC.

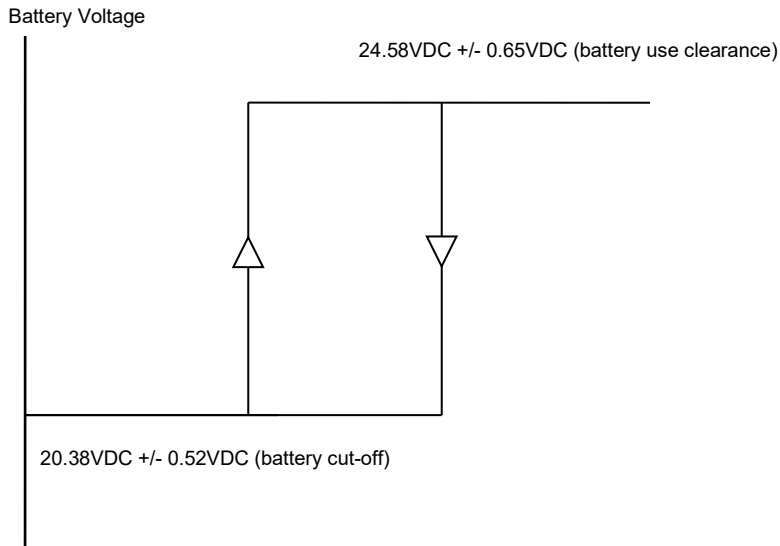

6.4.2 External DC availability

HWSSUB13 The system shall cut-off external DC supply if the external DC voltage drop below 9.49VDC +/- 0.12VDC and the system shall allow again the use of external DC supply if the external DC voltage goes back above 10.27VDC +/- 0.13VDC.

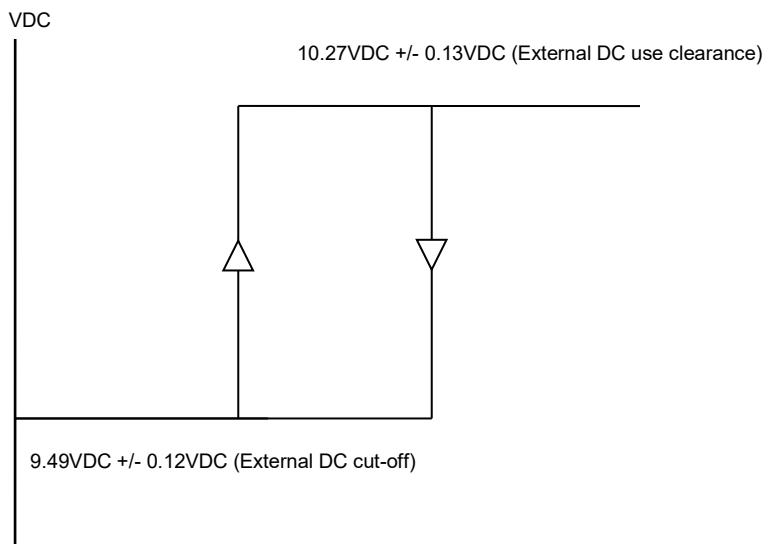

COVIDIEN 6135 Gunbarrel Avenue Boulder, CO 80301 Proprietary and Confidential	TITLE: Power Supply Board Hardware Requirements Specification, PB 540	DOCUMENT NUMBER 10025029 SHEET 11 of 19	REV E
---	---	--	-----------------

PROPRIETARY & CONFIDENTIAL

FOR INTERNAL USE ONLY

This document may not be copied, disclosed, or used in whole or in part without the consent of COVIDIEN.

© 2008 COVIDIEN All Rights Reserved.

7.0 COOLING FAN FUNCTIONS

HWSSUB20 The Power Supply board shall measure board temperature within a range from -30°C to +80°C with an accuracy of +/-3°C.

HWSSUB21 The Power Supply board shall provide a fan driver to provide temperature control for the board and battery temperatures.

HWSSUB22 The driver shall be able to generate a fan speed command by providing a PWM signal on the fan supply.

HWSSUB23 The PWM signal shall have a frequency of 123 kHz +/- 5%.

HWSSUB25 The cooling fan shall be supplied a voltage within the range of 8V to 24VDC.

8.0 REGULATOR FUNCTIONS

8.1 24V Regulator

HWSSUB30 The Power Supply board shall provide a 24VDC (+/-1.2VDC at currents < 2A, and +1.2V/-2V at currents \geq 2A) output voltage with 3A capacity from the VACDC Output

HWSSUB31 The Power Supply board shall provide a 24VDC (+/-1.2VDC at currents < 2A, and +1.2V/-2V at currents \geq 2A) output voltage with 3A capacity from the external DC power supply.

HWSSUB32 The Power Supply board shall provide a 24VDC (+/-1.2VDC at currents < 2A, and +1.2V/-2V at currents \geq 2A) output voltage with 3A capacity from the internal battery.

HWSSUB33 The 24VDC regulator shall have a 4A current limit (+/- 400mA).

HWSSUB34 The Power Supply board shall provide a monitor for the 24V voltage regulator from 22V to 26V with a +/-0.1V precision.

8.2 5V Regulator

HWSSUB35 The Power Supply board shall provide a 5VDC +/-0.25V voltage with 1A output current from the VACDC Output.

HWSSUB36 The Power Supply board shall provide a 5VDC +/-0.25V voltage with 1A output current from external DC power supply.

HWSSUB37 The Power Supply board shall provide a 5VDC +/-0.25V voltage with 1A output current from the internal battery.

HWSSUB38 The Power Supply board shall provide a voltage monitor for the 5V regulator with a range of 4.5V to 5.5V with an accuracy of +/-60mV.

8.3 3,3V Regulator

HWSSUB39 The Power Supply board shall provide a 3.3VDC +/-0.16V voltage with 500mA output current from 3.3V regulator output.

HWSSUB40 The Power Supply board shall provide a voltage monitor for the 3.3V regulator with a range of 3.0V to 3.6V with an accuracy of +/-10mV.

8.4 3V reference regulator

HWSSUB41 The Power Supply board shall provide a 3V +/-18mV voltage reference with 3mA capacity from a 3V regulator output.

COVIDIEN 6135 Gunbarrel Avenue Boulder, CO 80301 Proprietary and Confidential	TITLE: Power Supply Board Hardware Requirements Specification, PB 540	DOCUMENT NUMBER 10025029 SHEET 12 of 19	REV E
---	---	--	-----------------

PROPRIETARY & CONFIDENTIAL

FOR INTERNAL USE ONLY

This document may not be copied, disclosed, or used in whole or in part without the consent of COVIDIEN.

© 2008 COVIDIEN All Rights Reserved.

9.0 SYSTEM INTERFACES

9.1 USB gateway

HWSSUB42 The gateway shall integrate a numeric calculator. It will be programmable in circuit. This circuit is used to manage all the Host USB functions: Read, Write, Erase...etc.

HWSSUB43 The Power Supply board USB gateway shall be able to receive a reset flag signal from CPU board through the ribbon cable (J7 - 11).

HWSSUB44 The Power Supply board USB gateway shall be able to provide a busy flag signal to CPU board through the ribbon cable (J7 - 12).

9.2 CPU board interface

HWSSUB45 The Power Supply board calculator shall communicate with CPU board through a SPI bus (# 0) to transfer data.

HWSSUB46 The Power Supply board shall provide a communication path to allow communication between the CPU board and the USB gateway through an SPI bus (# 1).

HWSSUB47 The Power Supply board shall provide a signal for AC supply presence (keyboard led management) to the CPU through the ribbon cable (J7 - 15).

HWSSUB82 The Power Supply board shall provide a signal for DC supply presence (keyboard led management) to the CPU through the ribbon cable (J7 - 16)

HWSSUB83 The Power Supply board shall provide a signal for battery supply presence (keyboard led management) to the CPU through the ribbon cable (J7 - 17)

HWSSUB49 The Power Supply board shall provide the battery voltage to the CPU through the ribbon cable (J7 - 14).

9.3 PC / System Communication

HWSSUB51 The Power Supply board shall provide a communication channel to allow a PC to communicate with the Calculator at 115000 Baud communication speed through a USB port (mini B).

HWSSUB50 The Power Supply board shall allow data transmission between a PC and the CPU board through a UART communication at 256000 Baud.

9.4 Turbine board interface

HWSSUB52 The Power Supply board shall provide a +24VDC +/-1.2VDC power source to turbine command board with a 3A maximum current capacity.

COVIDIEN 6135 Gunbarrel Avenue Boulder, CO 80301 Proprietary and Confidential	TITLE: Power Supply Board Hardware Requirements Specification, PB 540	DOCUMENT NUMBER 10025029 SHEET 13 of 19	REV E
---	---	--	-----------------

PROPRIETARY & CONFIDENTIAL

FOR INTERNAL USE ONLY

This document may not be copied, disclosed, or used in whole or in part without the consent of COVIDIEN.

© 2008 COVIDIEN All Rights Reserved.

9.5 Interconnects

9.5.1 USB B Connector – J1

PIN NUMBER	SIGNAL NAME	PIN NUMBER	SIGNAL NAME
1	+ VUSB	2	Data-
3	Data+	4	ID
5	- Ground	6	- Ground
7	- Ground		

9.5.2 ICSP – PIC Programmer – J2

PIN NUMBER	SIGNAL NAME	PIN NUMBER	SIGNAL NAME
1	MCLR	2	+ +5V Supply
3	- Ground	4	PGD
5	PGC	6	NC

9.5.3 Output AC/DC Power Supply Connector – J3

PIN NUMBER	SIGNAL NAME	PIN NUMBER	SIGNAL NAME
1	+ VACDC	2	+ VACDC
3	+ VACDC	4	+ VACDC
5	- Power Ground	6	- Power Ground
7	- Power Ground	8	- Power Ground
9	+ VACDC	10	+ VACDC
11	+ VACDC	12	+ VACDC

COVIDIEN 6135 Gunbarrel Avenue Boulder, CO 80301 Proprietary and Confidential	TITLE: Power Supply Board Hardware Requirements Specification, PB 540	DOCUMENT NUMBER	REV
		10025029	E
		SHEET 14 of 19	

PROPRIETARY & CONFIDENTIAL

FOR INTERNAL USE ONLY

This document may not be copied, disclosed, or used in whole or in part without the consent of COVIDIEN.

© 2008 COVIDIEN All Rights Reserved.

9.5.4 Input AC/DC Power Supply Connector – J4

PIN NUMBER	SIGNAL NAME	PIN NUMBER	SIGNAL NAME
1	AC Neutral	2	NC
3	AC Phase		

9.5.5 External DC Connector – J5

PIN NUMBER	SIGNAL NAME	PIN NUMBER	SIGNAL NAME
1	+ VDCEXT	2	+ VDCEXT
3	+ VDCEXT	4	- Power Ground
5	- Power Ground	6	- Power Ground
7	- Ground	8	- Ground
9	- Ground	10	- Ground

9.5.6 Cooling Fan Connector – J6

PIN NUMBER	SIGNAL NAME	PIN NUMBER	SIGNAL NAME
1	+ Supply	2	- Ground

COVIDIEN 6135 Gunbarrel Avenue Boulder, CO 80301 Proprietary and Confidential	TITLE: Power Supply Board Hardware Requirements Specification, PB 540	DOCUMENT NUMBER	REV
		10025029 SHEET 15 of 19	E

PROPRIETARY & CONFIDENTIAL

FOR INTERNAL USE ONLY

This document may not be copied, disclosed, or used in whole or in part without the consent of COVIDIEN.

© 2008 COVIDIEN All Rights Reserved.

9.5.7 CPU Board Connector – J7

PIN NUMBER	SIGNAL NAME	PIN NUMBER	SIGNAL NAME
1	- Power Ground	2	- Analogic Ground
3	+ 24V Supply	4	- Ground
5	SCLK SPI #1	6	SCLK SPI #0
7	MTSR SPI 0	8	CE SPI PIC
9	MRST SPI 0	10	CE SPI USB
11	RESET USB	12	USB BUSY
13	+ 5V Supply	14	+ Battery Supply
15	AC LED	16	DC LED
17	BATTERY LED	18	MRST SPI 1
19	TX UART ST10	20	RX UART ST10
21	RTS UART ST10	22	MTSR SPI 1
23	+ 24V Supply	24	- Ground
25	- Power Ground	26	- Analogic Ground

9.5.8 Turbine Board Supply Connector – J9

PIN NUMBER	SIGNAL NAME	PIN NUMBER	SIGNAL NAME
1	- Power Ground	2	+ +24V Supply

COVIDIEN 6135 Gunbarrel Avenue Boulder, CO 80301 Proprietary and Confidential	TITLE: Power Supply Board Hardware Requirements Specification, PB 540	DOCUMENT NUMBER	REV
		10025029	E
		SHEET 16 of 19	

PROPRIETARY & CONFIDENTIAL

FOR INTERNAL USE ONLY

This document may not be copied, disclosed, or used in whole or in part without the consent of COVIDIEN.

© 2008 COVIDIEN All Rights Reserved.

9.5.9 Battery Connector – J10

PIN NUMBER	SIGNAL NAME	PIN NUMBER	SIGNAL NAME
1	- Power Ground	2	- Power Ground
3	- Power Ground	4	- Power Ground
5	Temperature	6	EEPROM
7	+ VBAT	8	+ VBAT
9	+ VBAT	10	+ VBAT

9.5.10 USB A #1 Connector – J12

PIN NUMBER	SIGNAL NAME	PIN NUMBER	SIGNAL NAME
1	+ VUSB	2	Data-
3	Data+	4	- Ground
5	- Ground	6	- Ground

9.5.11 USB A #2 Connector – J13

PIN NUMBER	SIGNAL NAME	PIN NUMBER	SIGNAL NAME
1	+ VUSB	2	Data-
3	Data+	4	- Ground
5	- Ground	6	- Ground

9.5.12 USB EEPROM Programmer Connector – J14

PIN NUMBER	SIGNAL NAME	PIN NUMBER	SIGNAL NAME
4	+ +3.3V Supply	2	SDA
3	SCL	1	- Ground

COVIDIEN 6135 Gunbarrel Avenue Boulder, CO 80301 Proprietary and Confidential	TITLE: Power Supply Board Hardware Requirements Specification, PB 540	DOCUMENT NUMBER	REV
		10025029	E
		SHEET 17 of 19	

PROPRIETARY & CONFIDENTIAL

FOR INTERNAL USE ONLY

This document may not be copied, disclosed, or used in whole or in part without the consent of COVIDIEN.

© 2008 COVIDIEN All Rights Reserved.

10.0 MECHANICAL REQUIREMENTS

10.1 Size

- HWSSUB53 The length (L1) of the PCBA shall be 6.7mm +/- 1mm
- HWSSUB54 The length (L2) of the PCBA shall be 12.2mm +/- 1mm
- HWSSUB55 The length (L3) of the PCBA shall be 167.3mm +/- 1mm
- HWSSUB56 The length (L4) of the PCBA shall be 19mm +/- 1mm
- HWSSUB57 The length (L5) of the PCBA shall be 26mm +/- 1mm
- HWSSUB58 The length (L6) of the PCBA shall be 15.4mm +/- 1mm
- HWSSUB59 The length (L7) of the PCBA shall be 19.8mm +/- 1mm
- HWSSUB60 The length (L8) of the PCBA shall be 15mm +/- 1mm
- HWSSUB61 The width (W1) of the PCBA shall be 29.75mm +/- 1mm
- HWSSUB62 The width (W2) of the PCBA shall be 6mm +/- 1mm
- HWSSUB63 The width (W3) of the PCBA shall be 61.7mm +/- 1mm
- HWSSUB64 The width (W4) of the PCBA shall be 5.3mm +/- 1mm
- HWSSUB65 The width (W5) of the PCBA shall be 6.3mm +/- 1mm
- HWSSUB66 The width (W6) of the PCBA shall be 16.9mm +/- 1mm
- HWSSUB67 The width (W7) of the PCBA shall be 32.2mm +/- 1mm
- HWSSUB68 The width (W8) of the PCBA shall be 80mm +/- 1mm
- HWSSUB69 The thickness (T) of the PCBA shall be 1.6mm +/- 0.5mm

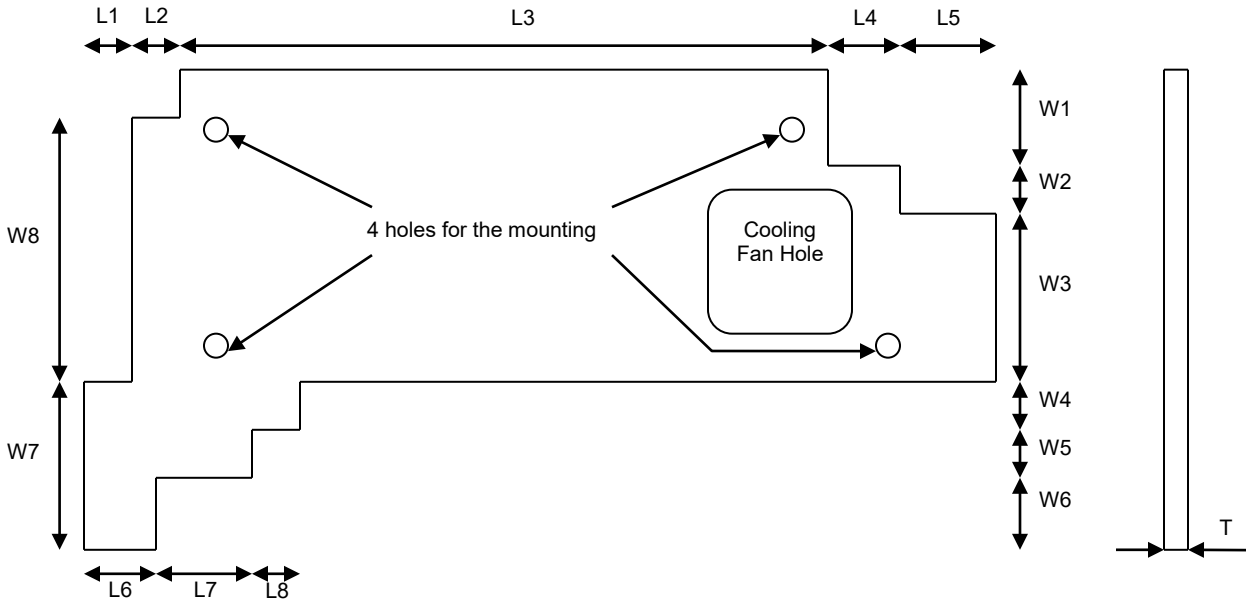

10.2 Mounting

- HWSSUB70 4 holes \varnothing 4.6mm shall be plan to fix the CPU board on the device
- HWSSUB71 1 square 45mm x 44mm shall be provided to place the cooling fan.

10.3 Cooling

N/A.

COVIDIEN 6135 Gunbarrel Avenue Boulder, CO 80301 Proprietary and Confidential	TITLE: Power Supply Board Hardware Requirements Specification, PB 540	DOCUMENT NUMBER 10025029 SHEET 18 of 19	REV E
---	---	--	-----------------

PROPRIETARY & CONFIDENTIAL

FOR INTERNAL USE ONLY

This document may not be copied, disclosed, or used in whole or in part without the consent of COVIDIEN.

© 2008 COVIDIEN All Rights Reserved.

10.4 Fabrication

HWSSUB72 The Printed Circuit Board shall be fabricated with the standard:
IPC-A-610D Class III: 2005, Acceptability for Electronic Assemblies.
Exceptions shall be listed on the fabrication drawings.

10.5 Protection

HWSSUB73 A plastic cover shall be added on the both AC/DC Supply heatsink.

10.6 Labelling

HWSSUB74 The PCBA shall be labeled with its Name, Part Number and Revision which is also human readable.

11.0 PACKAGING REQUIREMENTS

HWSSUB75 Packaging shall be designed to minimize the level of waste and waste disposal as per the European Directive on handling waste packaging.

HWSSUB76 Packaging shall be tested to the international standard ISTA2A.

COVIDIEN 6135 Gunbarrel Avenue Boulder, CO 80301 Proprietary and Confidential	TITLE: Power Supply Board Hardware Requirements Specification, PB 540	DOCUMENT NUMBER 10025029 SHEET 19 of 19	REV E
---	---	--	-----------------

PROPRIETARY & CONFIDENTIAL

FOR INTERNAL USE ONLY

This document may not be copied, disclosed, or used in whole or in part without the consent of COVIDIEN.

© 2008 COVIDIEN All Rights Reserved.