

1

2

3

4

5

6

A

A

B

B

C

C

D

D

E

E

F

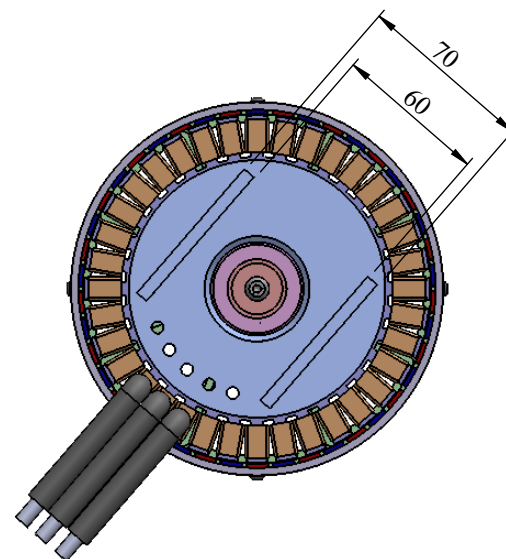
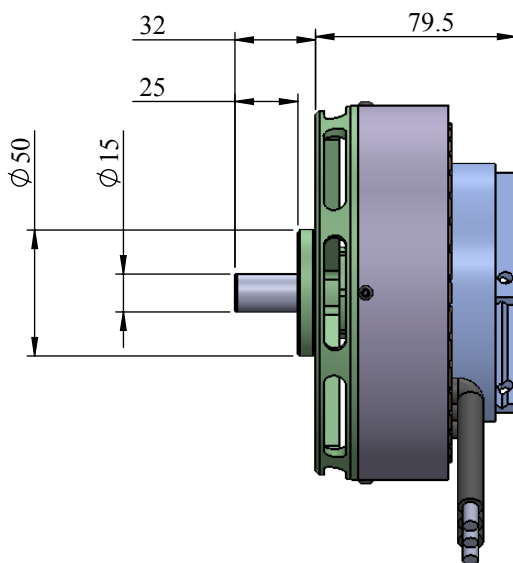
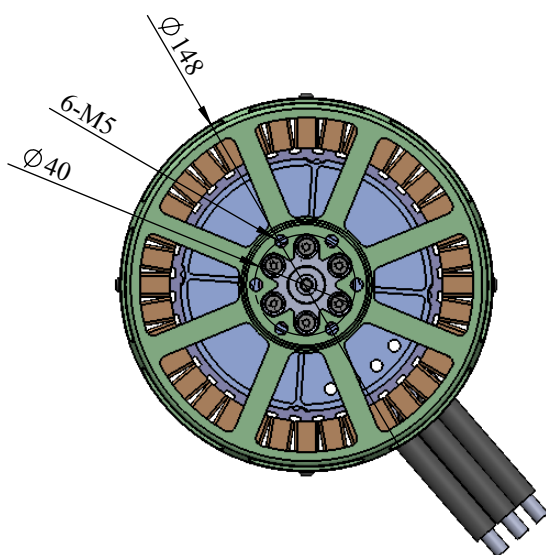
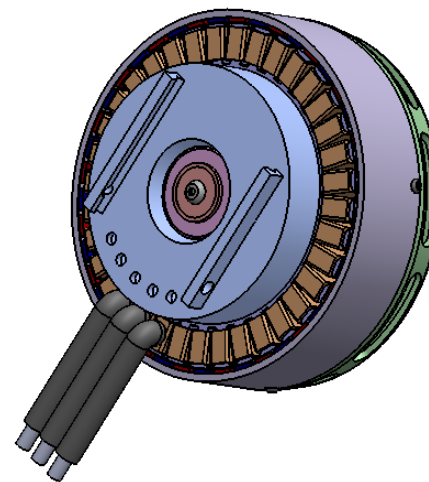
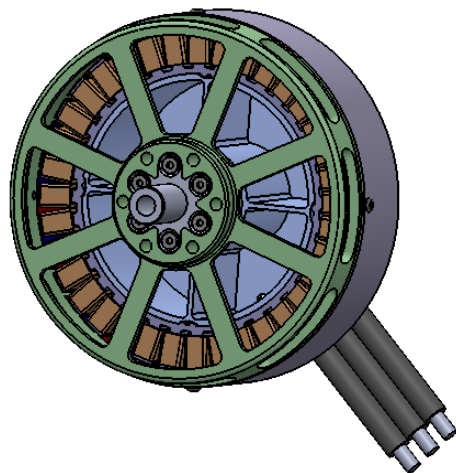

本資料為工研院專有之財產,非經書面許可,不准透露或使用本資料,亦不准複印,複製或轉變成任何其他形式使用。

The Information contained herein is the exclusive property of ITRI and shall not be distributed, prior written permission of ITRI.

加工條件(參考DIN7168-1970) 2級(細)	表面粗度	Rmax	日期 DATE	2026-05-11	 工業技術研究院 Industrial Technology Research Institute	修正 REV	A
	TOLERANCES ON ANGLES ±0.1° DECIMALS	▽	100S以內	單位 UNIT		mm	圖號 DRW NO.
超過 0.5-6 = ±0.1 超過 6-30 = ±0.2 超過 30-120 = ±0.3 超過 120-315 = ±0.5 超過 315-1000 = ±0.8	▽▽	25S以內	比例 SCALE	1:3	品名 PART	MD1508P外觀圖	
	▽▽▽	6.3S以內	製圖 DRAWN	張朝信	材質 MATERIAL		
	▽▽▽▽	0.8S以內	確認 CHECKED		處理 FINISH	數量 NUMBER	
	⊕		核准 APPROVED		備註 REMARK		
						SHEET 1 OF 1	

1

2